

90° ADJUSTABLE ADAPTOR MALE ORFS – MALE UNF WITH O-RING (1)

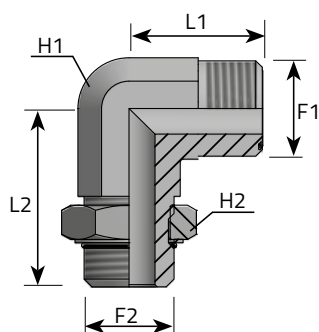

GOMITO 90° MASCHIO ORFS MASCHIO UNF ORIENTABILE CON O-RING
 ADAPTATEUR ORIENTABLE COUDE 90° MÂLE ORFS – MÂLE UNFADAPTER
 90° GSK-AG-ORFS / AG-UNF MIT O.R.
 CODO 90° ORIENTABLE MACHO ORFS – MACHO UNF CON O-RING

F1 ORFS

F2 UNF

Code	Thread		Dimensions				Pressure	
	F1	F2	H1	H2	L1	L2	Bar	Psi
			mm	mm	mm	mm		
LMO06MOU04	9/16	7/16	14	14	21.5	32.5	420	6091
LMO09MOU06	11/16	9/16	19	17	25	37	420	6091
LMO11MOU08	13/16	3/4	22	22	28	40.5	420	6091
LMO13MOU10	1	7/8	27	27	33.5	50	420	6091
LMO14MOU12	1.3/16	1.1/16	30	32	37.5	55	420	6091
LMO15MOU16	1.7/16	1.5/16	36	41	41.5	59.5	380	5511
LMO21MOU20	1.11/16	1.5/8	41	50	52	62	280	4060
LMO32MOU24	2	1.7/8	48	55	49	66	280	4060
LMO06MOU06	9/16	9/16	14	17	21.5	34.5	420	6091
LMO06MOU08	9/16	3/4	19	22	23.5	40.5	420	6091
LMO09MOU04	11/16	7/16	19	14	25	35	420	6091
LMO09MOU08	11/16	3/4	19	22	25	40.5	420	6091
LMO09MOU10	11/16	7/8	22	27	28	50	420	6091
LMO09MOU12	11/16	1.1/16	27	32	29.5	55	420	6091
LMO11MOU06	13/16	9/16	22	17	28	37	420	6091
LMO11MOU10	13/16	7/8	22	27	30	50	420	6091
LMO11MOU12	13/16	1.1/16	27	32	31.5	55	420	6091

90° ADJUSTABLE ADAPTOR MALE ORFS – MALE UNF WITH O-RING (2)

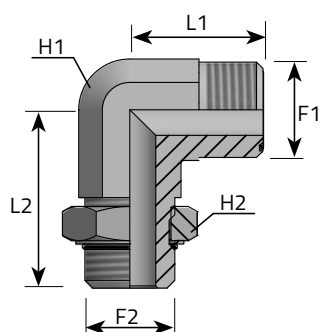

GOMITO 90° MASCHIO ORFS MASCHIO UNF ORIENTABILE CON O-RING
 ADAPTATEUR ORIENTABLE COUDE 90° MÂLE ORFS – MÂLE UNFADAPTER
 90° GSK-AG-ORFS / AG-UNF MIT O.R.
 CODO 90° ORIENTABLE MACHO ORFS – MACHO UNF CON O-RING

F1 ORFS

F2 UNF

Code	Thread		Dimensions				Pressure	
	F1	F2	H1	H2	L1	L2	Bar	Psi
			mm	mm	mm	mm		
LMO13MOU08	1	3/4	27	22	33.5	46	420	6091
LMO13MOU12	1	1.1/16	27	32	33.5	55	420	6091
LMO14MOU08	1.3/16	3/4	30	22	37.5	47	420	6091
LMO14MOU10	1.3/16	7/8	30	27	37.5	51	420	6091
LMO14MOU16	1.3/16	1.5/16	33	41	38	59.5	380	5511
LMO15MOU12	1.7/16	1.1/16	36	32	41.5	59	420	6091
LMO15MOU20	1.7/16	1.5/8	41	50	44.5	62	280	4060
LMO21MOU16	1.11/16	1.5/16	41	41	52	62	280	4060
LMO21MOU24	1.11/16	1.7/8	48	55	52	66	280	4060
LMO32MOU20	2	1.5/8	48	50	49	66	280	4060